

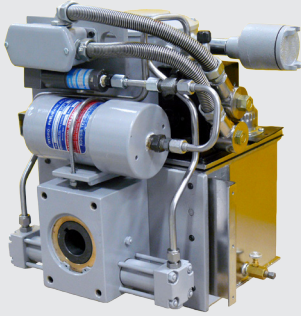

Enertech Nuclear Class Electro-Hydraulic Actuators

Enertech Nuclear Class Electro-Hydraulic Actuators

for Valve and Damper Control



Compact Rotary Damper

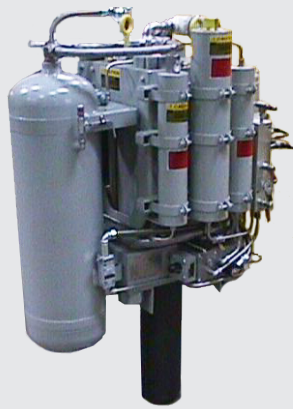

Fast Acting MFIV



Containment Butterfly Valve



Modulating Control Valve

Who We Are

Enertech, formerly Paul-Munroe Hydraulics, is a product and service brand of Curtiss-Wright Nuclear. Since 1967, Curtiss-Wright Nuclear has specialized in the supply of hydraulic equipment to the commercial nuclear power industry. In 1978, we recognized the need for a compact, fast-acting hydraulic actuator to meet the demanding requirements of safe plant shutdown and post-accident cycling for valve and damper applications, both inside and outside containment. For over 35 years, we have supplied valve and damper actuators that are qualified to stringent IEEE Standards for harsh environment conditions.

Design

The third generation Enertech Electro-Hydraulic Operator (EHO) is fully self-contained for linear and rotary applications. The integral gas accumulator provides motive force for fail-safe positioning upon loss of the electric command signal. The electric motor and hydraulic pump are IEEE qualified for post design basis event cycling following restoration of Class 1 power.

Curtiss-Wright Nuclear's advanced EHO technology is ideally suited for large gate valves such as main steam isolation valves where high thrust, fast-closing time of five seconds or less, and sustained isolation force are mandatory. They are also designed for small torque outputs, such as damper actuators found on control room ventilation and other critical HVAC applications. In addition, the modulating Enertech EHO is industry proven in severe service control valve throttling applications, including PWR main steam atmospheric relief and main feedwater regulation.

EHOs may be specified with one common hydraulic power unit containing an electric motor, pump and reservoir for fail-safe control of up to four valves or dampers. Remote, skid mounted accumulators are offered for additional post-accident cycling from stored energy capacity without Class 1 power.

Environmental Qualification and Quality Assurance

EHOs are used in nuclear safety and non-safety related applications around the world. Enertech EHOs have been successfully tested and qualified to IEEE 382, Case IV for inside containment design basis radiation, pressure, and temperature for safe plant shutdown use. Seismic, vibration, and chemical spray conditions have also been successfully met in accordance with IEEE 344 and 323 Standards.

All safety-related EHOs are manufactured under Curtiss-Wright Nuclear's Quality Assurance Program which complies with 10CFR50 Appendix B and NQA-1. Other nuclear quality standards for non-ASME governed plants may be specified.

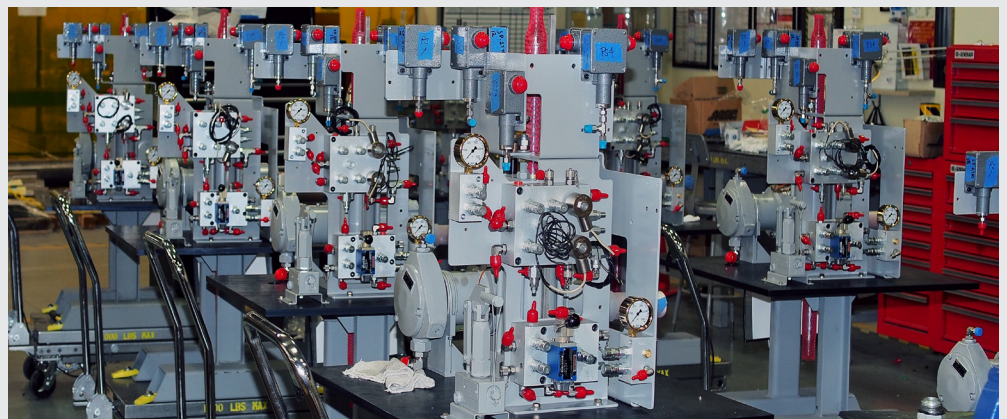

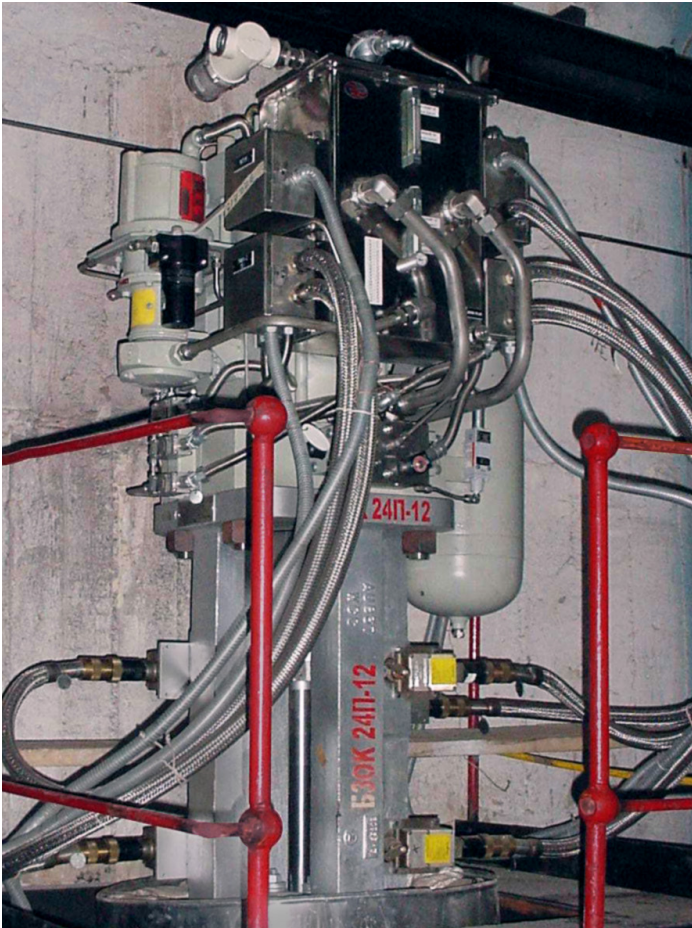

Replacement for Legacy Electro-Hydraulic Actuators

Curtiss-Wright Nuclear provides EHOs that are form, fit, and function replacements for obsolete units found in many Generation II nuclear plants. Enertech EHO's "gas-over-oil" design eliminates complex air pilot control sub loops found in competitors' older electro-hydraulic actuator designs. Commercially available sub-components assure uninterrupted aftermarket support for the life of your plant.

Curtiss-Wright Nuclear supplies engineering and service support for *all* legacy brands of nuclear EHOs.

With a large number of nuclear valve and damper control companies no longer supporting legacy brand electro-hydraulic actuators, Curtiss-Wright provides highly qualified engineering and technical services for obsolete equipment, including:

- ✓ Material obsolescence support
- ✓ Performance enhancements for thrust, closing time and reliability
- ✓ New generation, equivalent replacement actuators
- ✓ Seismic studies and upgrades
- ✓ Environmental qualification services
- ✓ Field and factory based refurbishment and test services
- ✓ Technical field supervision outage support
- ✓ Specialized, product specific field training services

EHO Nuclear Applications

MSIV / MFIV Actuator

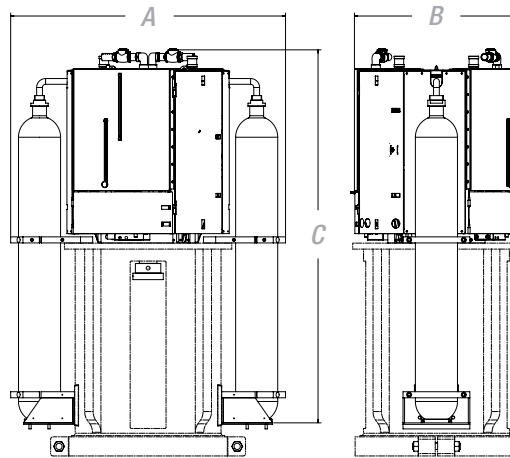

Rotary Actuator

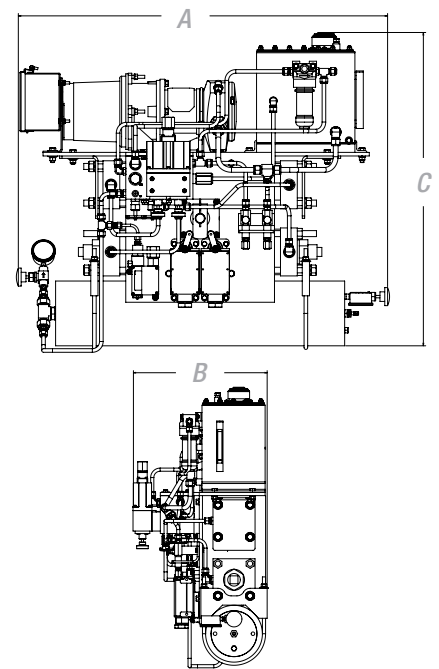

Product Description:	Self-contained linear fail closed for fast-acting isolation gate and globe valves.	Self-contained rotary fail closed for isolation butterfly and ball valves.
Features and Benefits:	<ul style="list-style-type: none"> • IEEE 382, 344 and 323 qualified • ASME QME-1 qualified • Air or electric driven pump for valve opening mode 	<ul style="list-style-type: none"> • IEEE 382, 344 and 323 qualified • Two speed closing for control of water hammer
Stroke Range:	8" - 36"	90° - 180°
Thrust Range:	50,000 - 300,000 lbs.	N/A
Torque Range:	N/A	20 - 300,000 ft.-lbs.
Weight Range:	5,000 - 12,000 lbs.	350 - 1,100 lbs.
"A" Dimension:	47" - 91"	28" - 36"
"B" Dimension:	47" - 54"	14" - 20"
"C" Dimension:	89" - 124"	24" - 27"
Emergency Mode:	Fail closed extend	Fail closed CW or CCW
Fast Acting Range:	3 - 30 seconds	5 - 30 seconds
Motive Force:	Stored Energy	Stored Energy
Qualification Life:	60 years	60 years

Large Bore Control Valve Modulating Actuator

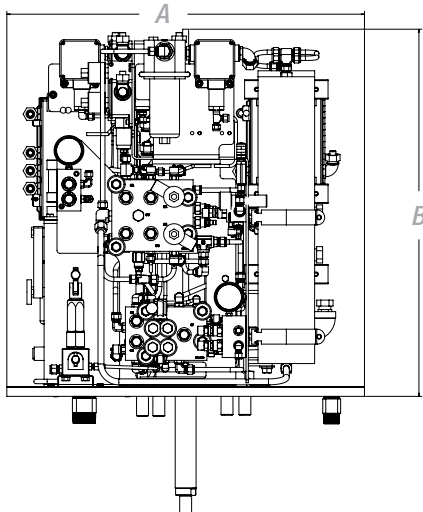

Small Bore Control Valve Modulating Actuator

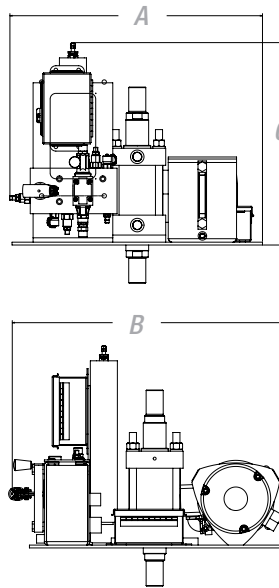

HVAC Damper Actuator

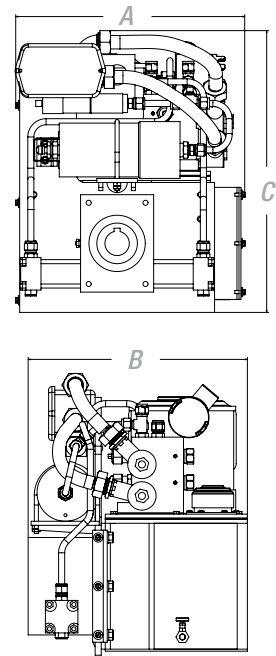

Self-contained linear Design Basis Event and Station Black Out modulating for control valves.	Self-contained linear Design Basis Event and Station Black Out modulating for control valves.	Self-contained rotary or linear fail closed for fast-acting isolation HVAC dampers.
<ul style="list-style-type: none"> • IEEE 382, 344 and 323 qualified • ASME QME-1 qualified • Post-accident valve cycling from stored energy and/or Class 1 electric motor 	<ul style="list-style-type: none"> • IEEE 382, 344 and 323 qualified • ASME QME-1 qualified • Post-accident valve cycling from stored energy and/or Class 1 electric motor 	<ul style="list-style-type: none"> • IEEE 382, 344, and 323 qualified • Compact and lightweight • Manual override
4" - 24"	1" - 4"	90° - 180° and 1" - 4"
5,000 - 50,000 lbs.	500 - 10,000 lbs.	N/A
N/A	N/A	820 in-lbs.
500 - 750 lbs.	200 lbs.	150 lbs.
25" - 30"	22"	14"
27" - 35"	18"	14"
24" - 30"	22"	17"
SBO modulating throttling	SBO modulating throttling	Fail closed CW or CCW
20 seconds	5 seconds	5 seconds
Stored Energy	Stored Energy	Stored Energy
60 years	60 years	60 years

EHO Design Qualification

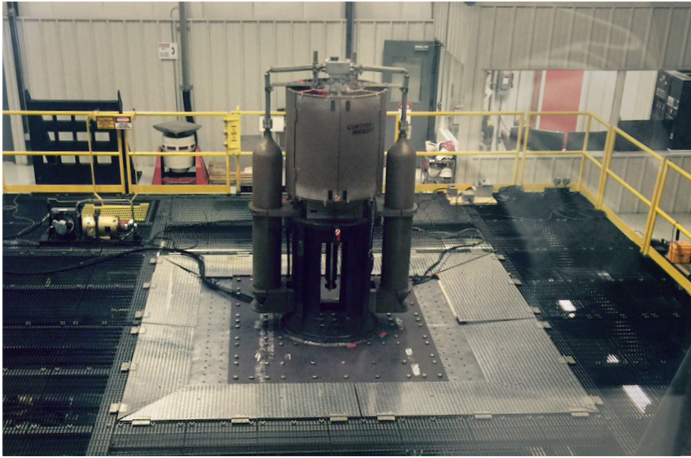

Major Components

- 1. Reservoir**
Stores hydraulic fluid and supplies the pump to maintain hydraulic pressure.
- 2. Pressure Switches**
Monitors the pressure of the nitrogen for fail-safe operation. They also maintain the accumulator pressure by turning the pump on or off at specified high or low pressure settings.
- 3. Hydraulic Cylinder**
Heavy duty, equal area design delivers consistent force when performing linear or rotary operation.
- 4. Solenoid Operated Valves (SOV)**
Provides directional control of the cylinder by diverting flow of the hydraulic fluid. SOVs are used for both modulating and two-position functionality.
- 5. Hydraulic Pump**
Maintains pressure in the accumulator. The pump receives signals from pressure switches.
- 6. Accumulator**
Provides stored energy for fail-safe positioning and post accident cycling.
- 7. Modulating Position Feedback**
IEEE qualified, high temperature potentiometer.

Design Validation

Curtiss-Wright Nuclear has successfully completed severe accident qualification of Enertech's fast-acting Electro-Hydraulic Valve Operator (EHO) to comply with stringent seismic standards that govern new generation Chinese nuclear plant construction. In order to satisfy ASME QME-1 and RCC-E requirements, Enertech previously demonstrated EHO performance to confirm adequate thrust for main steam line flow interruption by means of physical blow down test. This demanding test subjects a 32" main steam isolation valve (MSIV) with Enertech EHO to high energy main steam line break simulation of 6,000,000 pounds flow per hour and requires positive shut-off in less than 5 seconds.

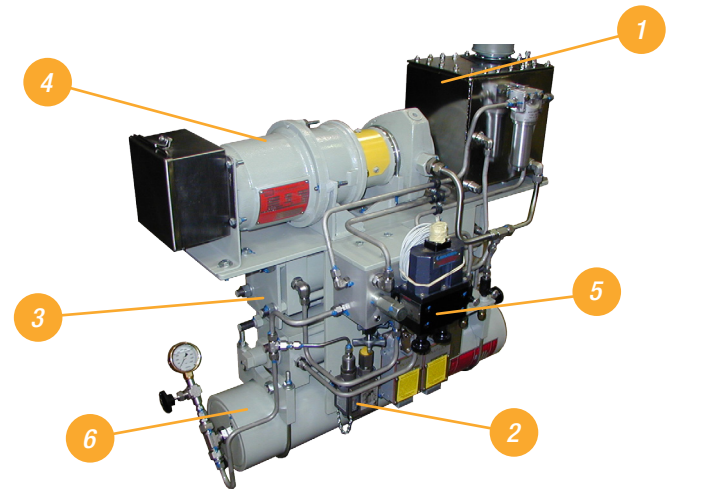

Rotary Operator

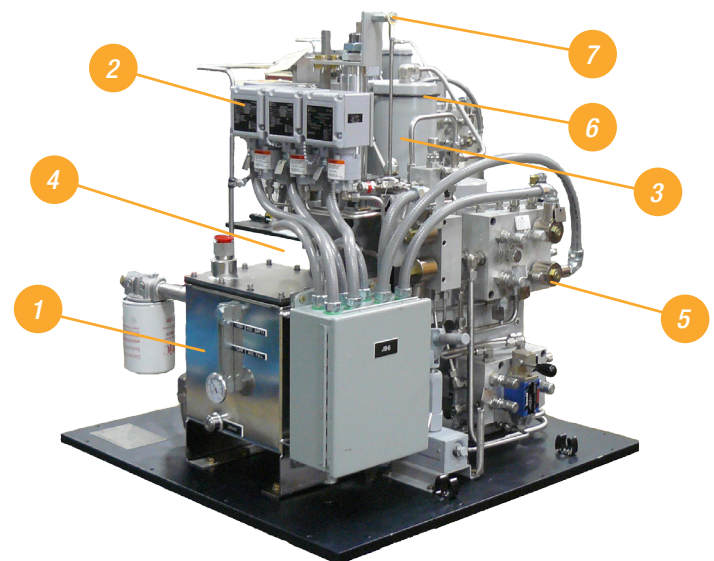

Linear Operator

Features, Benefits, and Additional Services

Why Enertech EHOs for Isolation and Throttling Applications?

	Electro-Hydraulic	Pneumatic	Electric Motor
Fast Acting (< 5 seconds)	X	X	
Fail Safe w/o Class 1 Power	X	X	X
Integral, Post-Accident Cycling	X		
No Air Supply Required	X		X
No Bulky Spring Packs Required	X		
Highest Thrust/Torque to Weight Ratio	X		
Less than 1% Positioning Error	X		X

Features

- **IEEE Qualified** – Inside and outside containment applications
- **Partial Stroke Option** – Periodic testing of valve operability
- **Less than 1% Modulation Error** – Precise control valve positioning
- **Compact Design** – Highest available thrust or torque output to weight/mass ratio
- **Dual Lock, Anti-Drift Design** – Prevention of position hunting
- **Two Speed, Anti-Slam Damping Option** – Mitigation of water hammer
- **Self Contained** – Safe plant shut down energy; no air or Class 1 power supply required
- **Hand Pump Over Ride** – Manual cycling
- **Fast Acting Response** – ANSI Class 900, 32" gate valve, Design Basis Event closure in less than 5 seconds. Closing time is independent of plant process condition and pressure

Additional Services

Condition Monitoring

Curtiss-Wright Nuclear provides a condition monitoring solution to ensure uninterrupted operation and provide the earliest indication of anomalies. Curtiss-Wright Nuclear's diagnostic system monitors the Enertech EHO's system pressure, temperature and motor cycling to trend and predict when maintenance is required, minimizing downtime.

Integrated Performance Testing

This system allows the user to perform the same factory acceptance test performed by Curtiss-Wright Nuclear including stroke, deadband, linearity, hysteresis, feedback position, and frequency response. These tests can be performed remotely, minimizing risk from inaccessible locations and radiation exposure to plant personnel.

Pump Skid Integration

Curtiss-Wright Nuclear offers complete ASME Section III pump skid design and fabrication services for modularized delivery of safety-related units. Curtiss-Wright Nuclear manufactures in accordance with ASME Section III, 10CFR50 Appendix B, Part 21 and NQA-1 for N Stamping of skid components and NPT Stamping of frame and connecting pipe. This includes seismic qualification of skid assemblies for critical to safety applications such as Diesel Generator Lube Oil Conditioning and Supply System.

Contact Information

Enertech

2950 E Birch Street
Brea, CA 92821
U.S.A.

P: +1.714.528.2301

F: +1.714.528.0128

E: enertech@curtisswright.com

www.cwnuclear.com

***CURTISS -
WRIGHT***

Curtiss-Wright Nuclear Headquarters: 2950 E Birch Street, Brea, CA 92821, U.S.A. | www.cwnuclear.com

Facilities: Berwick, PA | Cincinnati, OH | Clearwater, FL | Cromwell, CT | Danbury, CT | Freeport, PA | Hutchinson, MN | Huntsville, AL | Idaho Falls, ID | Middleburg Heights, OH | Mooresville, NC | Two Rivers, WI | Newmarket, Ontario, Canada

While this information is presented in good faith and believed to be accurate, Curtiss-Wright does not guarantee satisfactory results from reliance on such information. Nothing contained herein is to be construed as a warranty or guarantee, expressed or implied, regarding the performance, merchantability, fitness or any other matter with respect to the products, nor as a recommendation to use any product or process in conflict with any patent. Curtiss-Wright reserves the right, without notice, to alter or improve the designs or specifications of the products described herein.